

SECTION – HOME TURRET

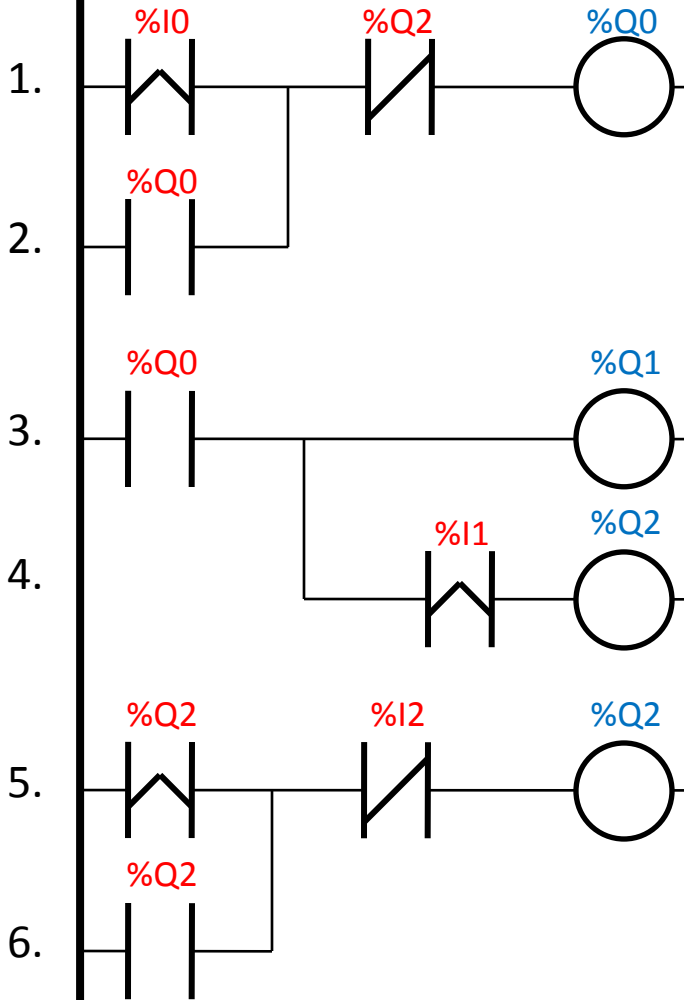

%I0 – Pyvcp-home-button
 %I1 – Encoder.Index-Pulse
 %I2 – Machine.Off

%Q0 – Find-Turret-Home
 %Q1 – Motor-CCW
 %Q2 – Turret-Homed

- Rung #1 – Pyvcp-Home-Button is pressed and the Find-Turret-Home is initiated.
- Rung #2 – Latch Find-Turret-Home until the turret is homed.
- Rung #3 – Find-Turret-Home turns on the motor.
- Rung #4 – Rising edge of the index-pulse in initiates Turret-Homed.
- Rung #5 – Rising edge of the of Turret-Homed initiates Turret-Homed.
- Rung #6 – Latch Turret-Homed until the machine is powered off.