

REV.	BESCHREIBUNG	DATUM	VON
TITEL			
7x12 Mini Lathe CNC Conversion			
DATUM	BESCHREIBUNG	SEITE	
05.08.2020	240VAC Power		1 VON 7

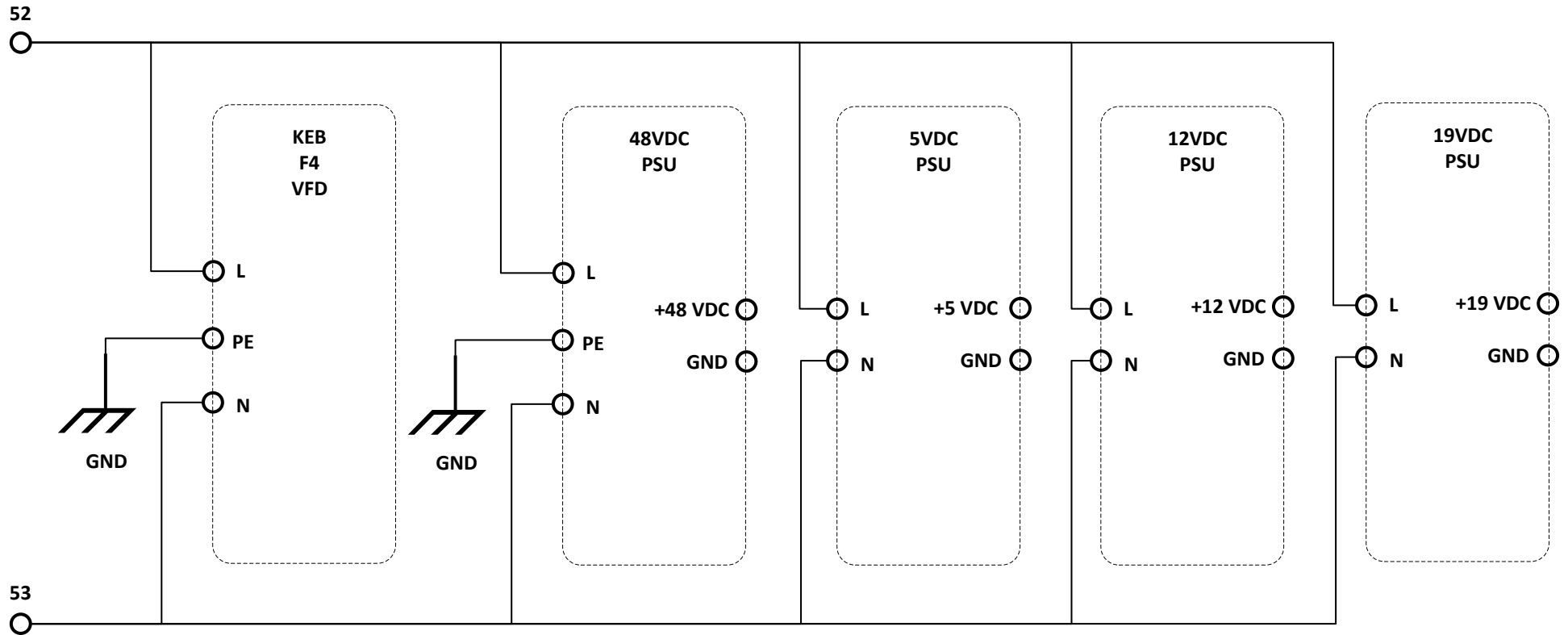

REV.	BESCHREIBUNG	DATUM	VON
TITEL			
7x12 Mini Lathe CNC Conversion			
DATUM	BESCHREIBUNG	SEITE	
05.08.2020	DC Power 1	2 VON 7	

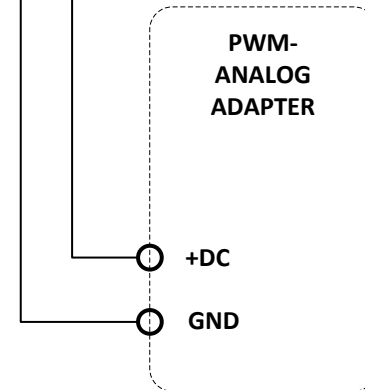
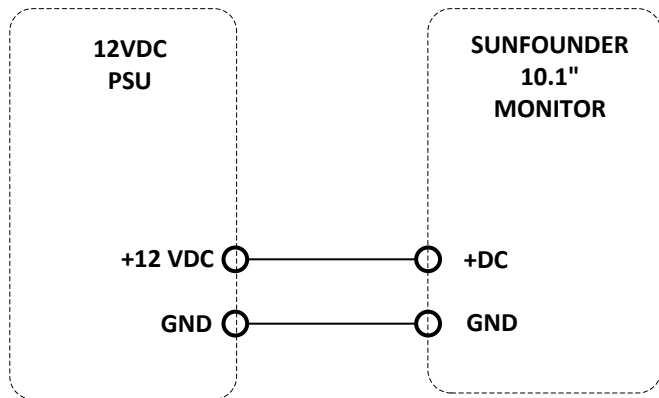
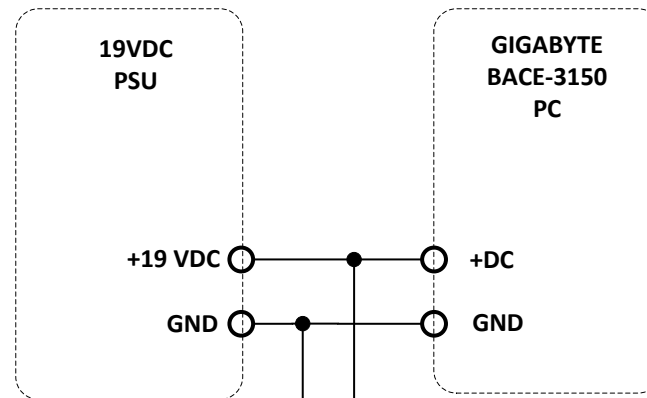
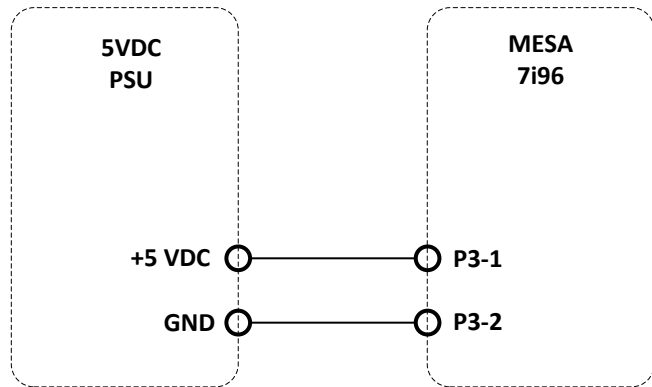

REV.	BESCHREIBUNG	DATUM	VON
TITEL			
7x12 Mini Lathe CNC Conversion			
DATUM	BESCHREIBUNG	SEITE	
05.08.2020	DC Power 2	3 VON 7	

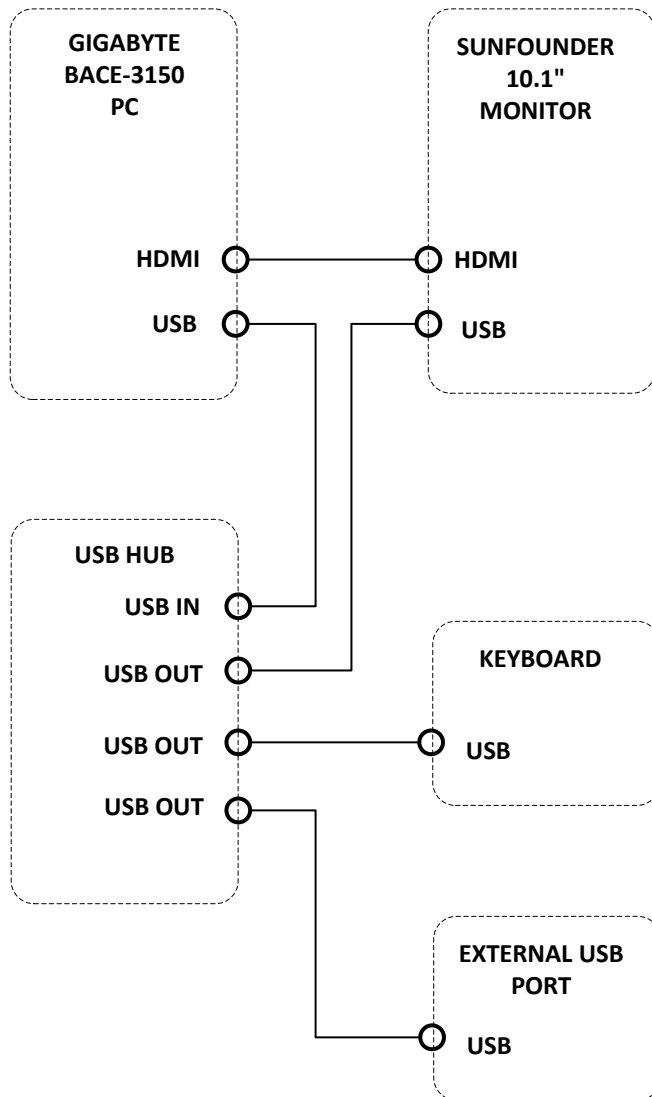

REV.	BESCHREIBUNG	DATUM	VON
TITEL			
7x12 Mini Lathe CNC Conversion			
DATUM	BESCHREIBUNG	SEITE	
05.08.2020	Computer	4 VON 7	

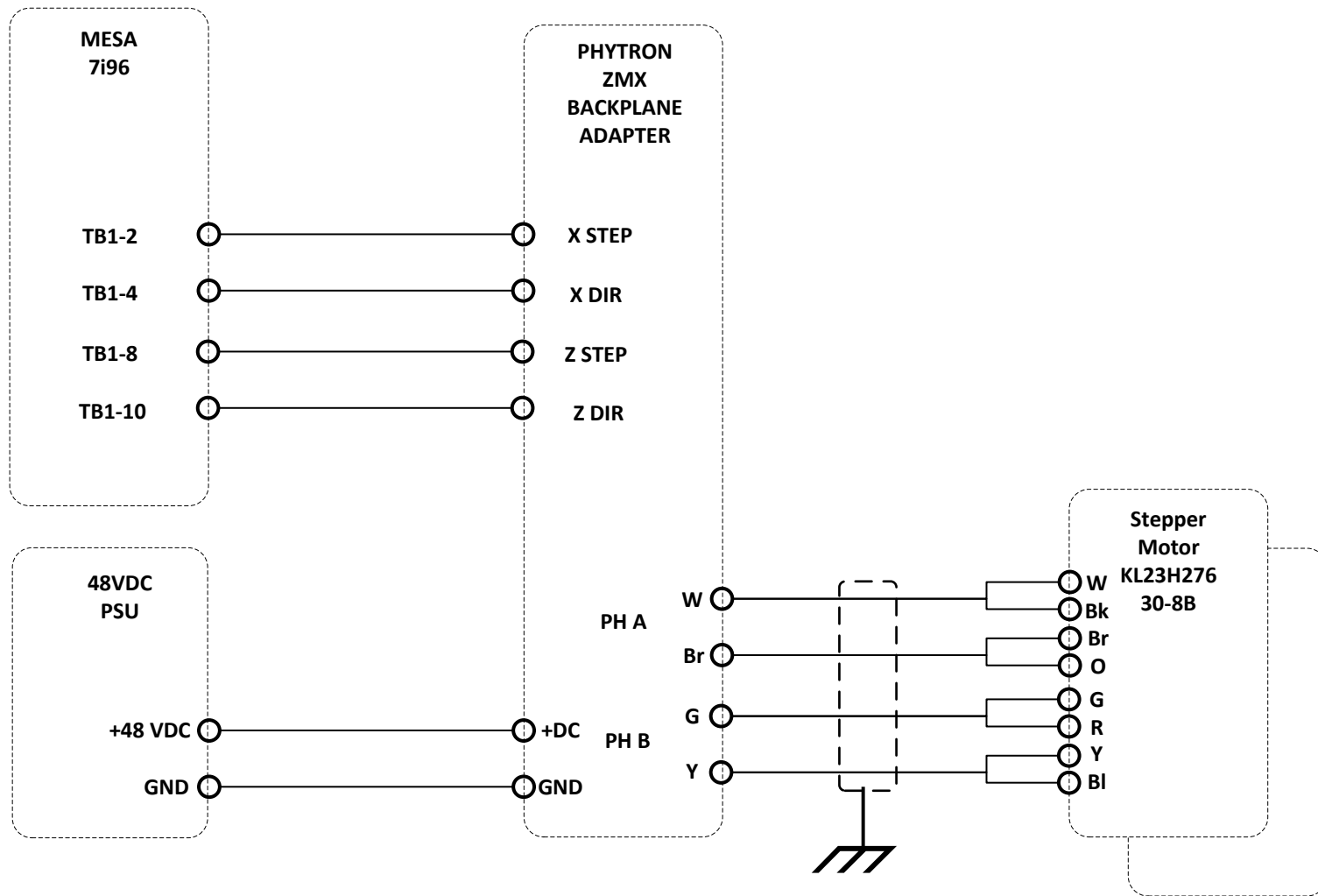

REV.	BESCHREIBUNG	DATUM	VON
TITEL			
7x12 Mini Lathe CNC Conversion			
DATUM	BESCHREIBUNG	SEITE	
05.08.2020	Stepper Motors	5 VON 7	

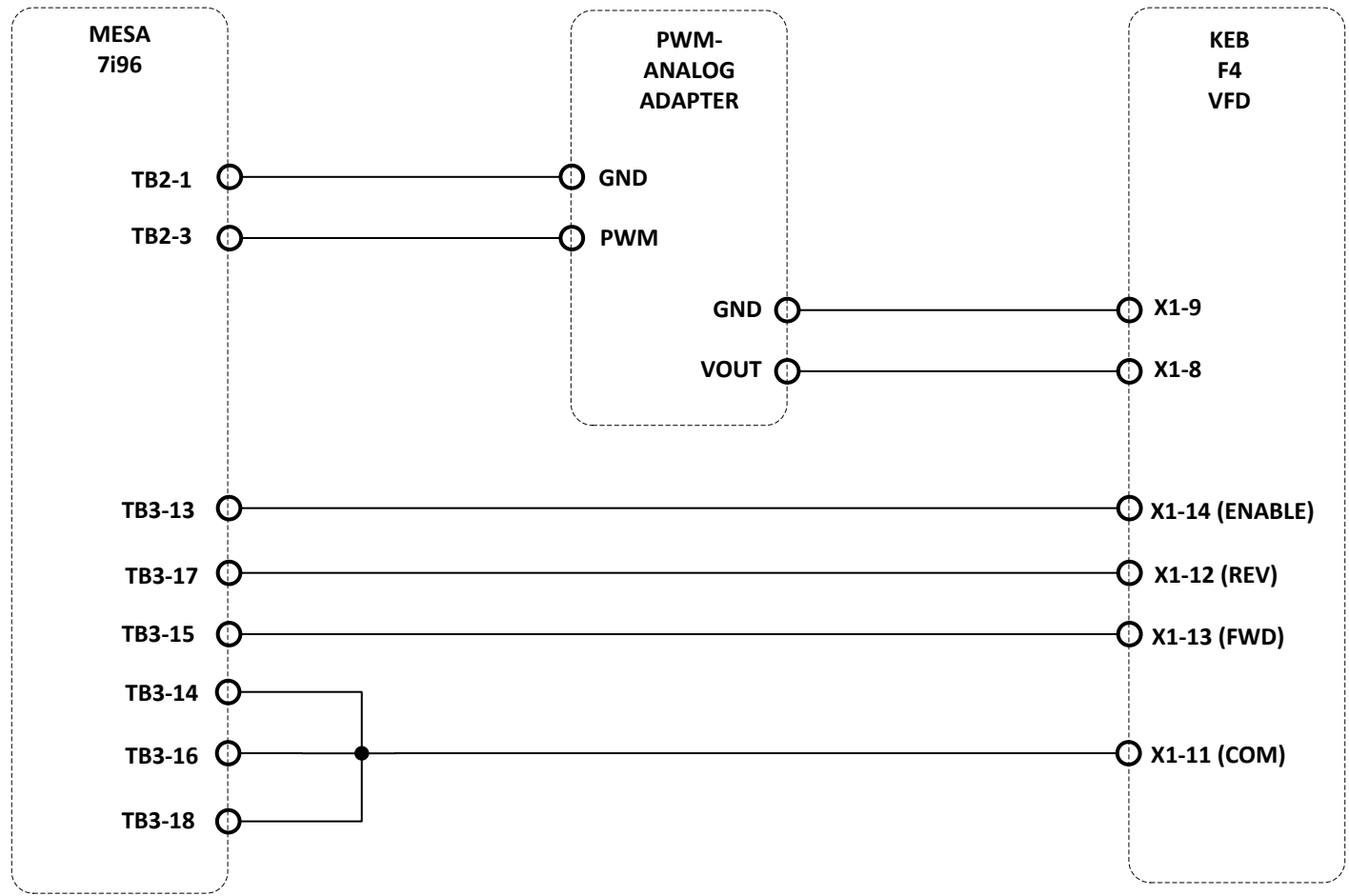

REV.	BESCHREIBUNG	DATUM	VON
TITEL			
7x12 Mini Lathe CNC Conversion			
DATUM	BESCHREIBUNG	SEITE	
05.08.2020	VFD	6 VON 7	

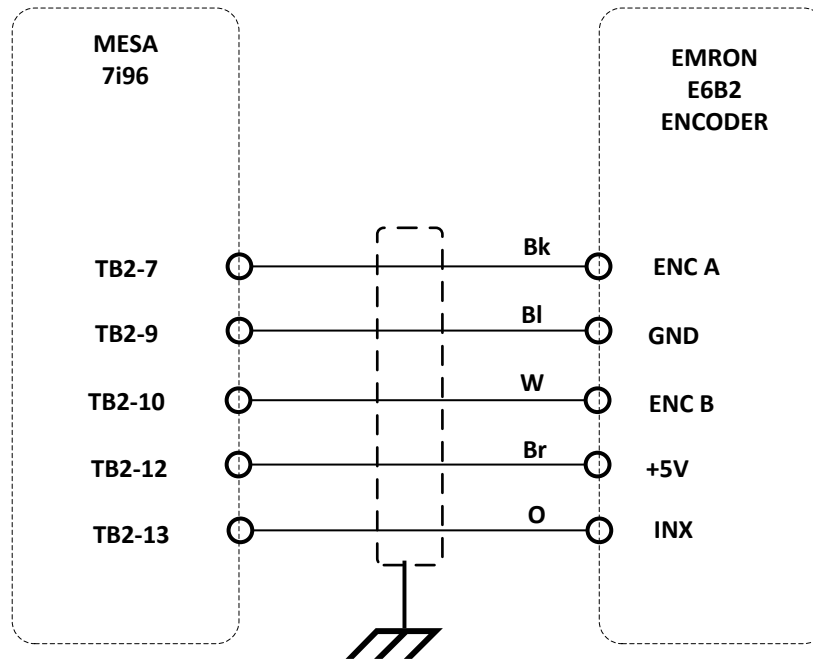

REV.	BESCHREIBUNG	DATUM	VON
TITEL			
7x12 Mini Lathe CNC Conversion			
DATUM	BESCHREIBUNG	SEITE	
05.08.2020	Encoder	7 VON 7	