

A

Flood coolant Run central lubrication Spindle tool release Mist coolant Cycle running Tool clamped

B



C

D

E

F

G

H

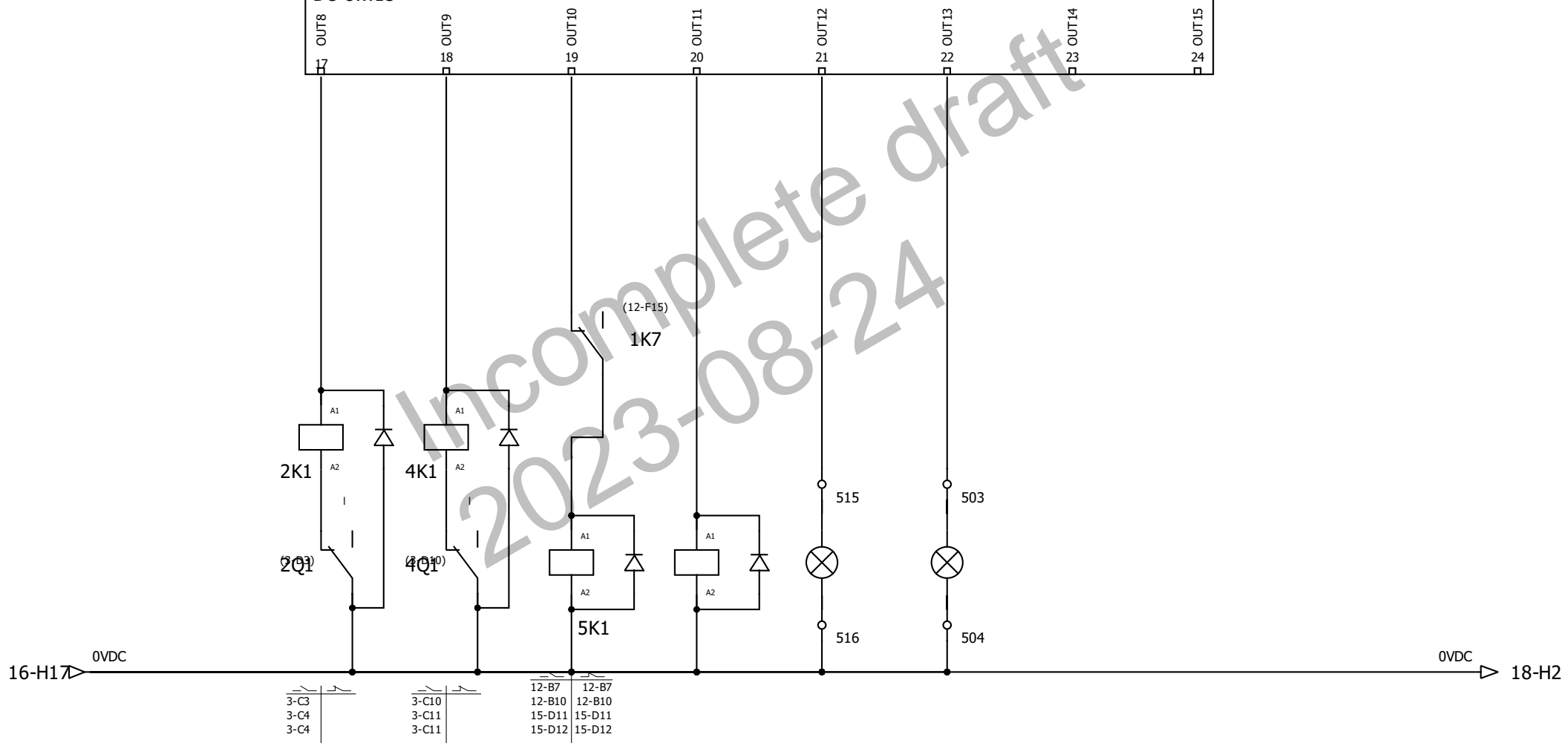

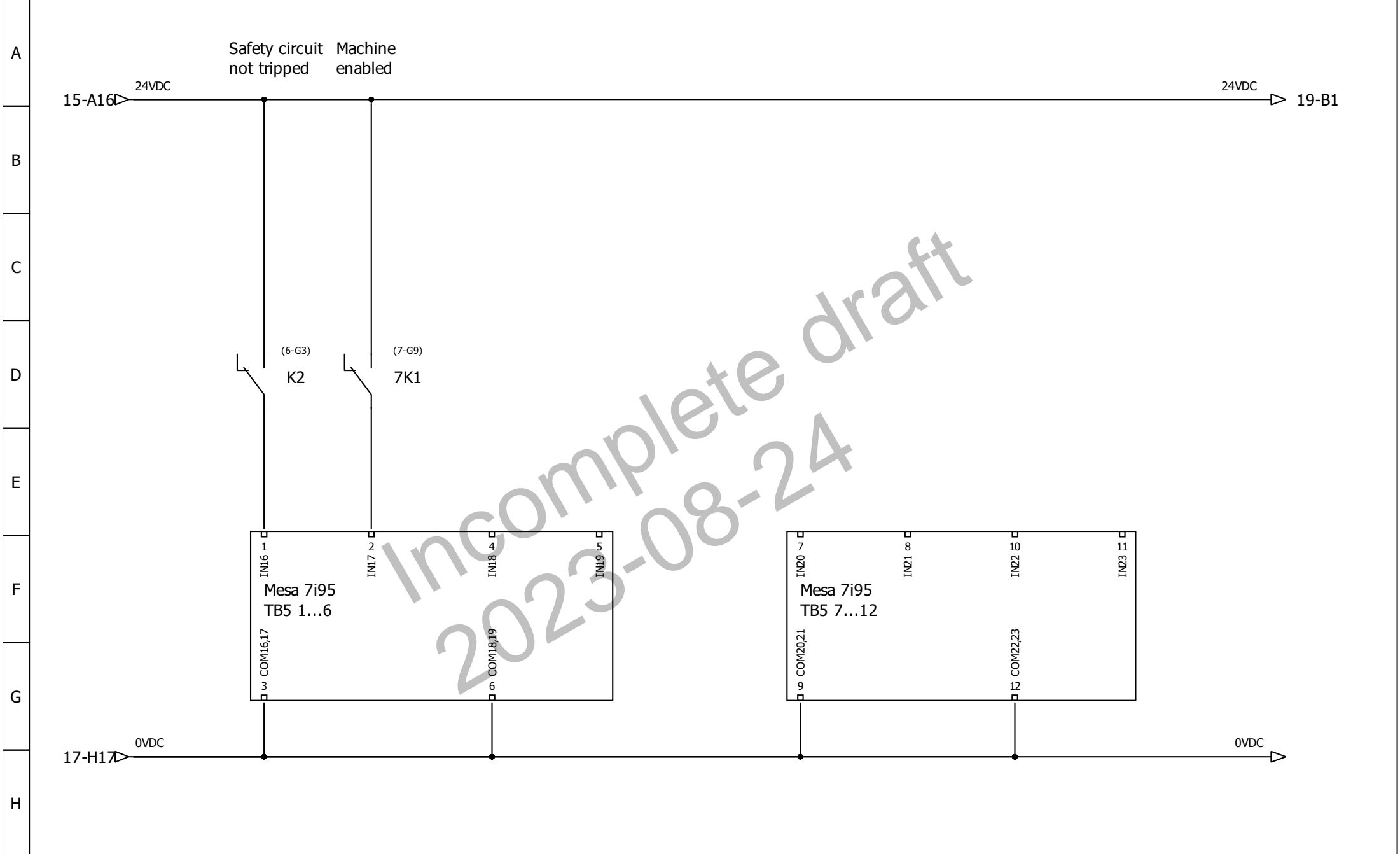

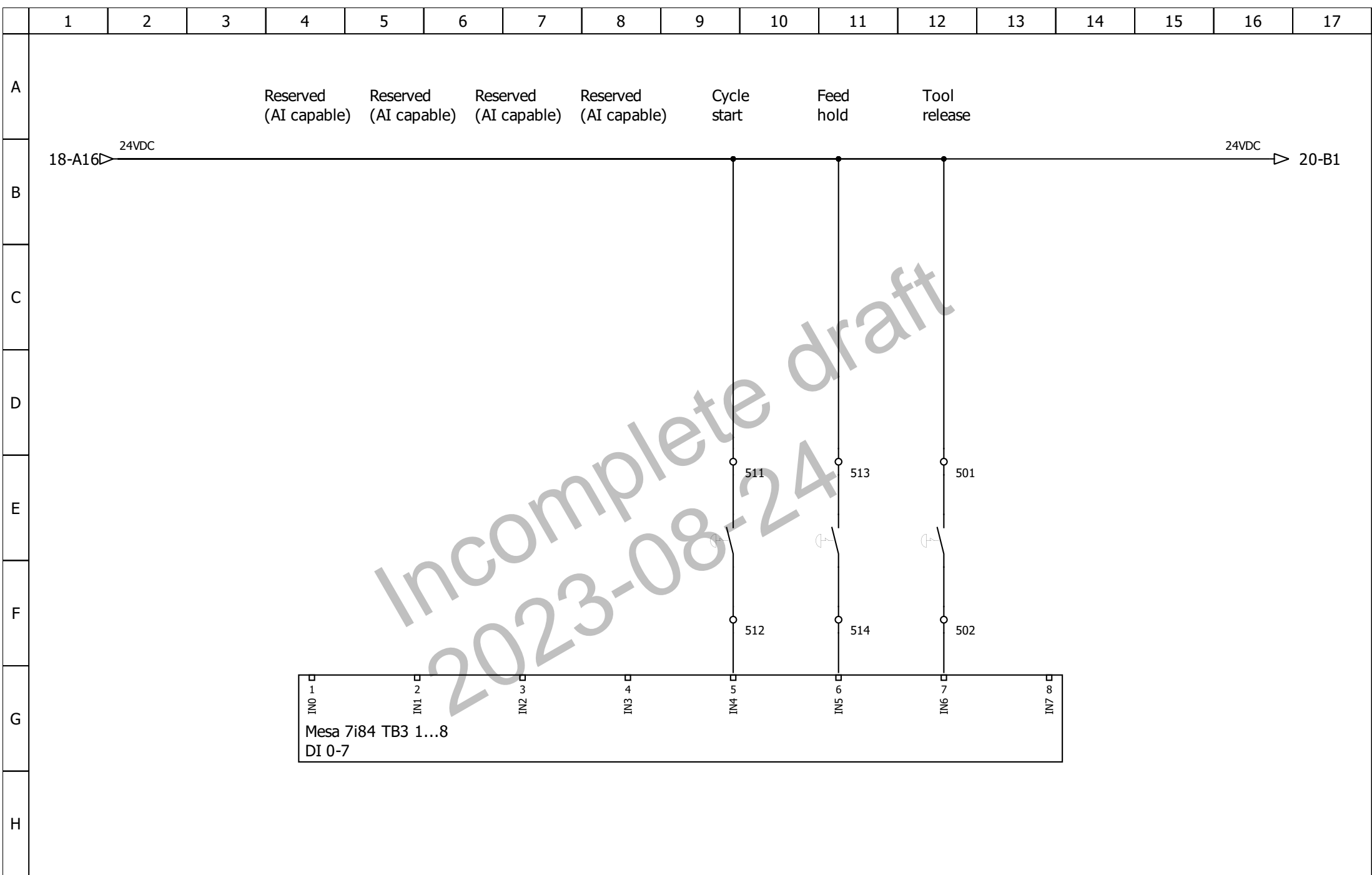

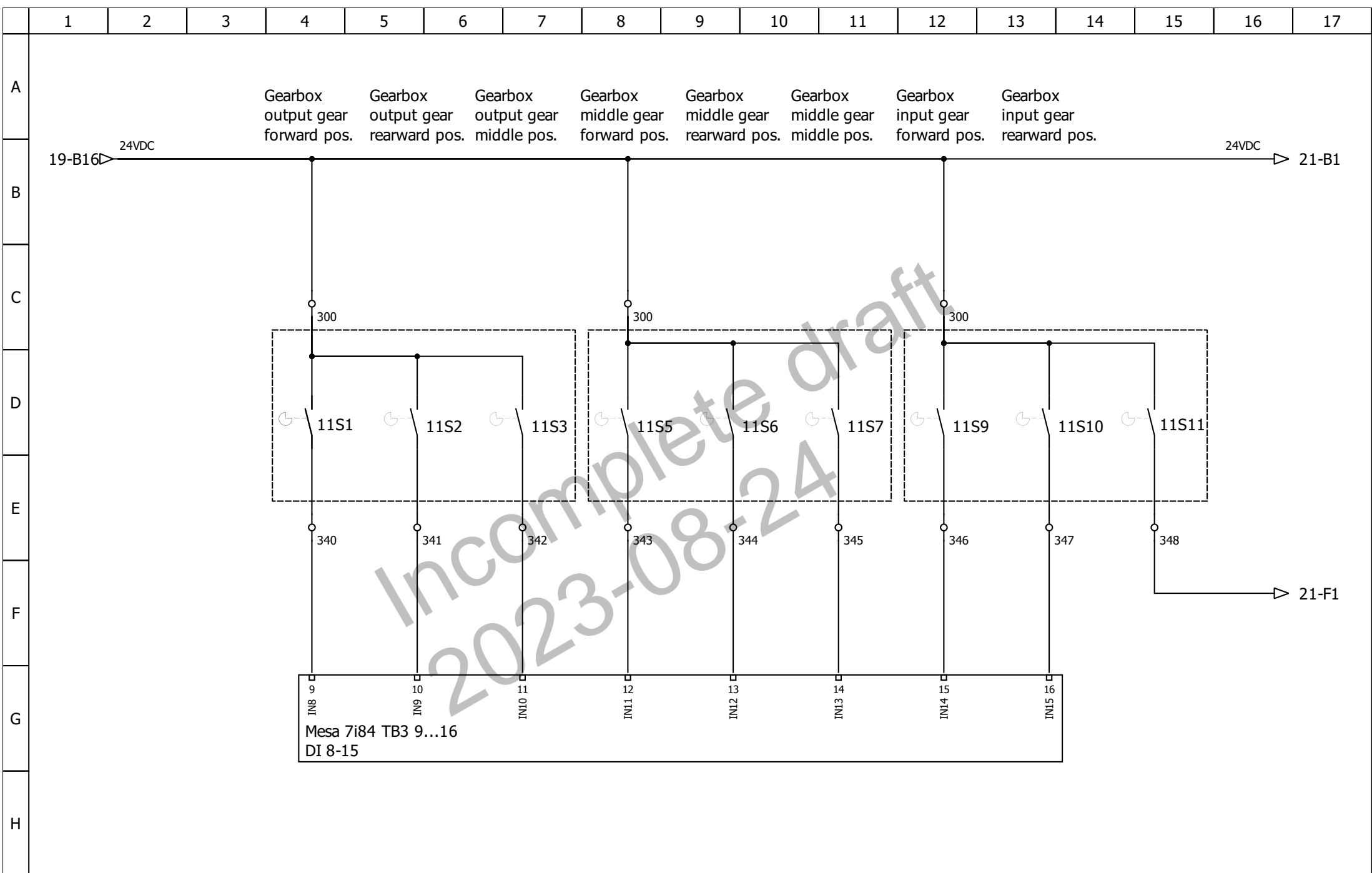

A
B
C
D
E
F
G
H

Gearbox input gear middle pos.
Central lubrication low level
Central lubrication pressure ok
Hydraulic pressure sufficient
Touch probe touching part
Tool length probe touch

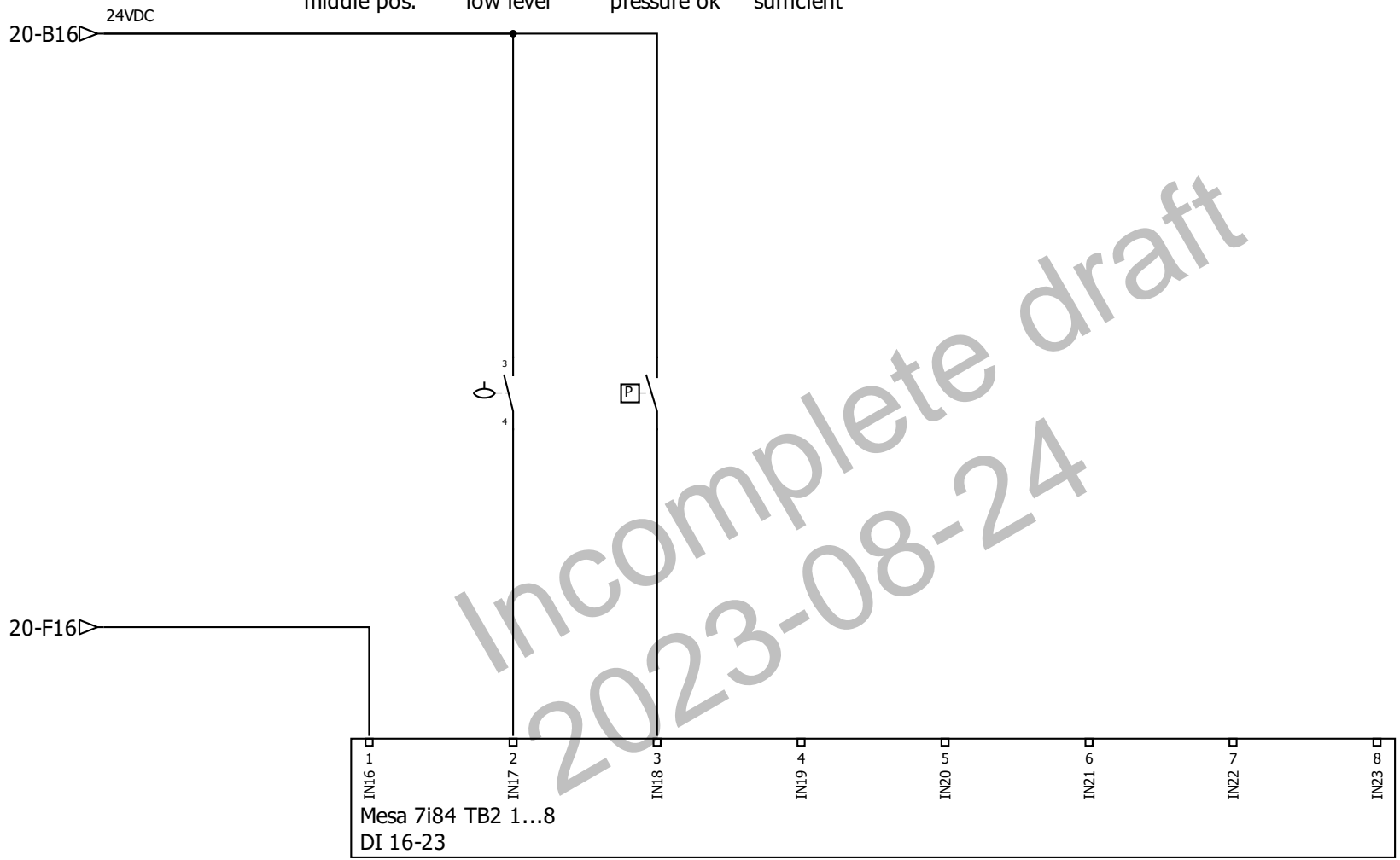

Incomplete draft
2023-08-24

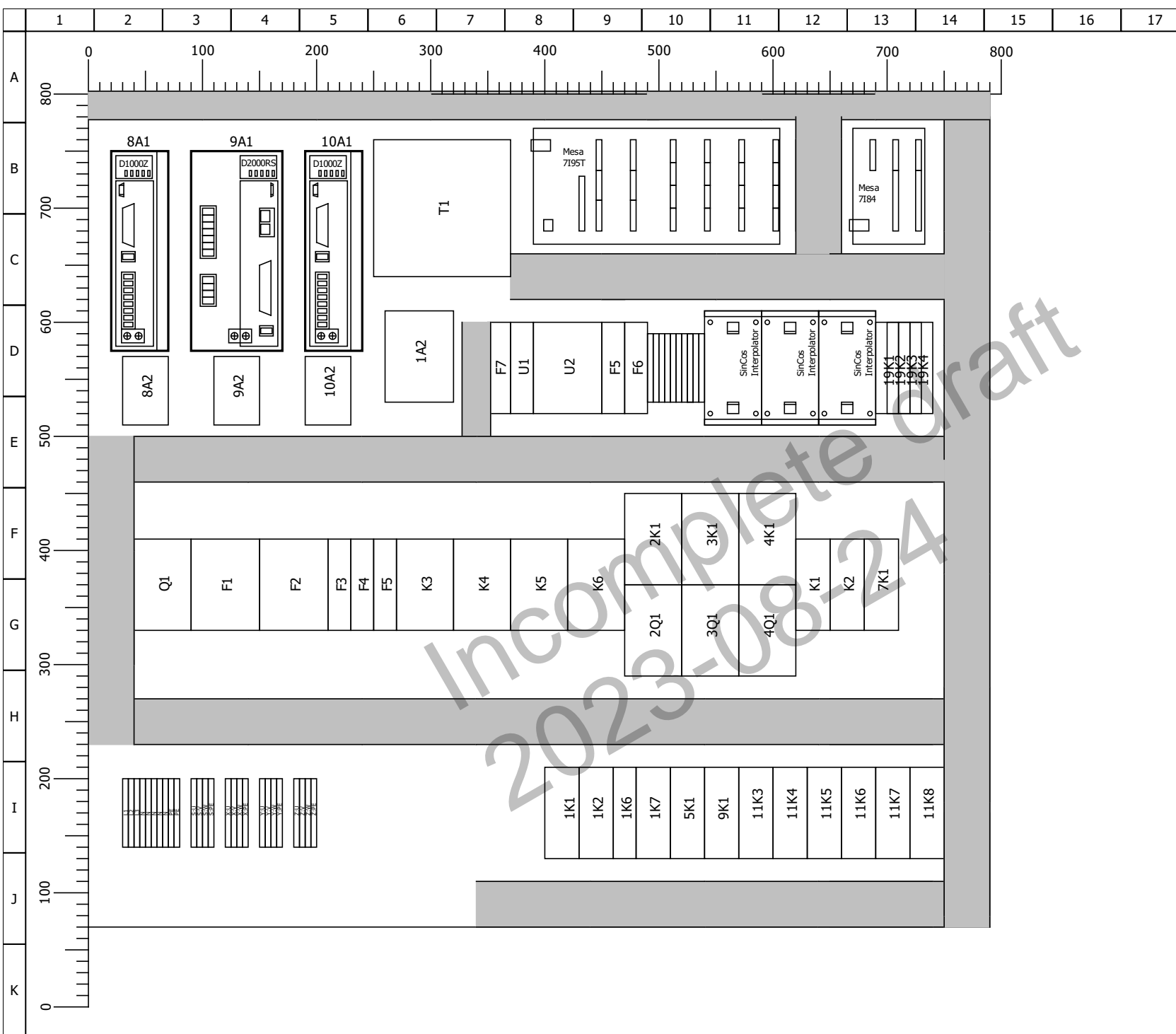

1

2

3

4

5

6

7

8

9

10

11

12

13

14

15

16

17

A

B

C

D

E

F

G

H

